

FILE NAME: V:\2002\active\2002005061\civil\drawing\sheet\Transmission Main Replacement\5061_C-WA-DIETL.dwg
 PLOTTING DATE: 5/18/2017 10:55 AM USER: Palmer, Logan

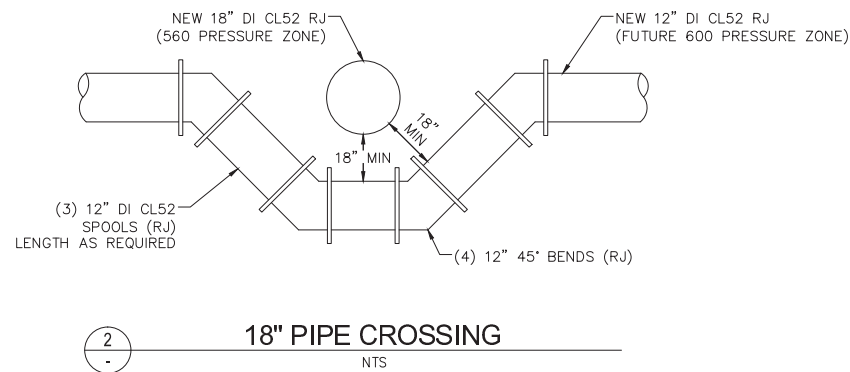

PRELIMINARY

NO.	DATE	BY	APPR.	REVISION

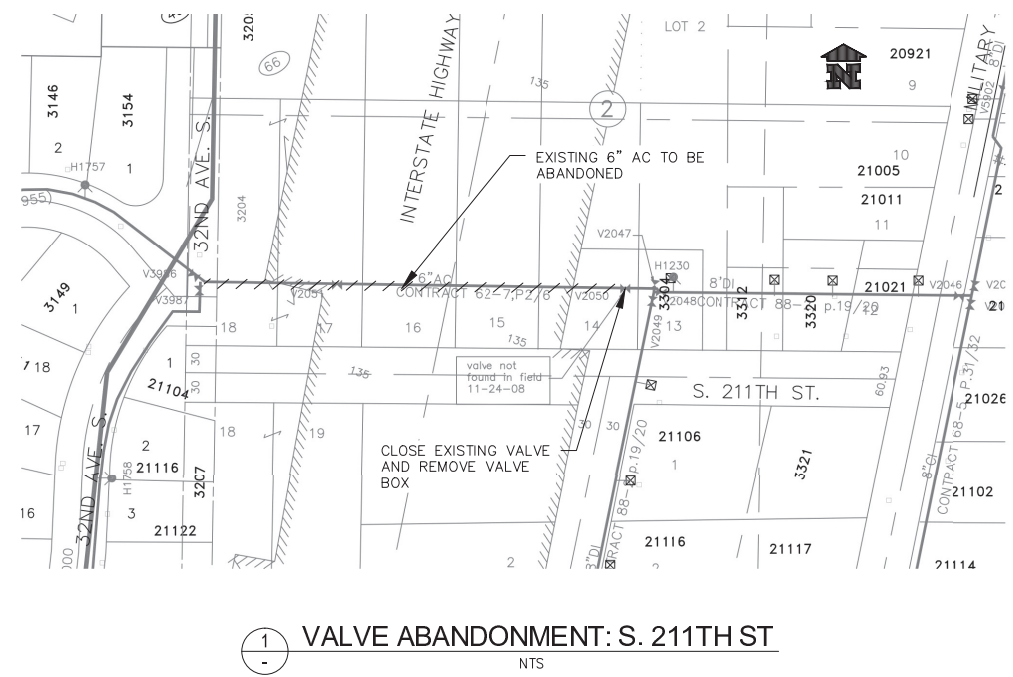
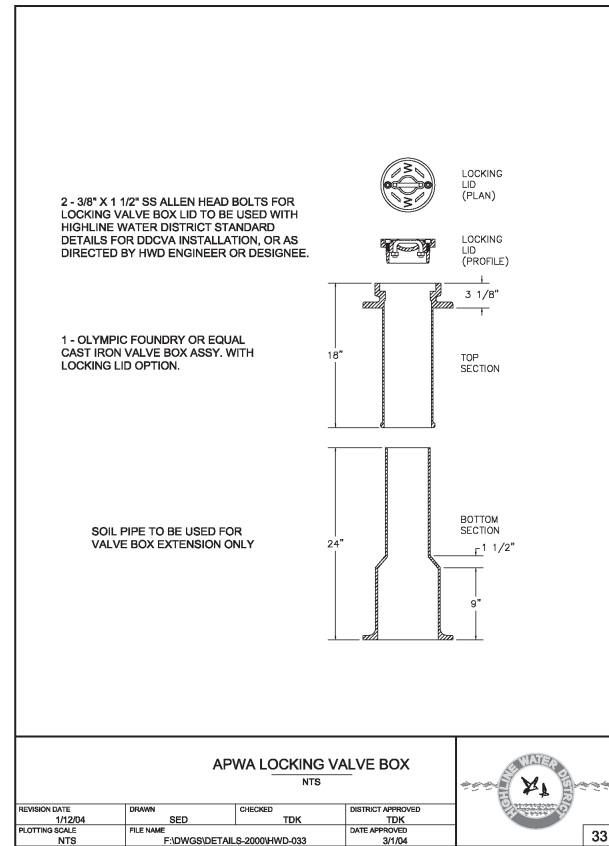
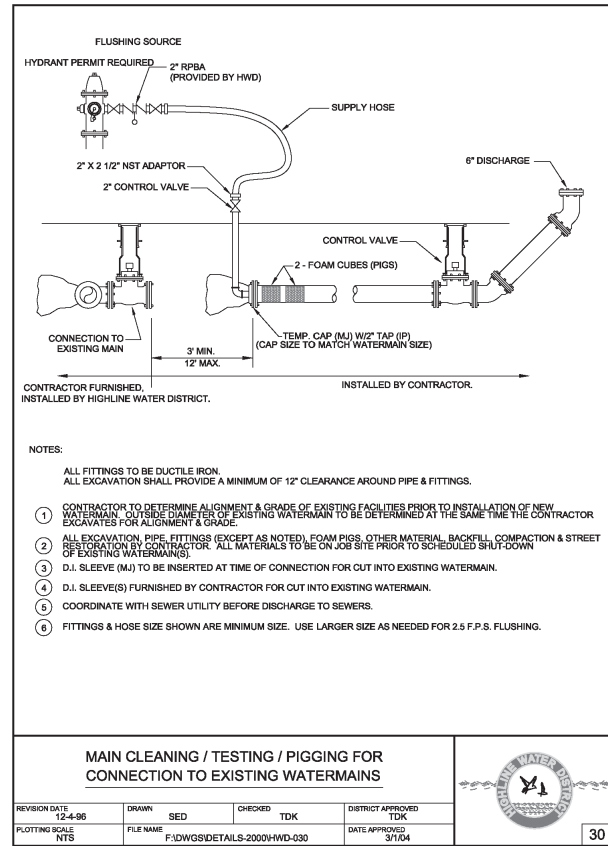

HIGHLINE WATER DISTRICT
 23828 30th Avenue South, Kent, Wa 98032
 Telephone: (206) 824-0375, Engineering

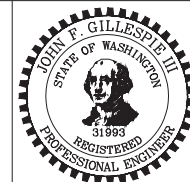

HIGHLINE WATER DISTRICT
 MANSION HILL 30" TRANSMISSION MAIN
 REPLACEMENT AND WATER MAIN IMPROVEMENTS
 STANDARD AND MISC WATER DETAILS

SHEET NO:
10
 10 15

DATE: SCALE: AS NOTED JOB # 2002005061

DRN. LRP DSGN. JG/LRP CHKD. JG