

CUT-IN TO MAINS

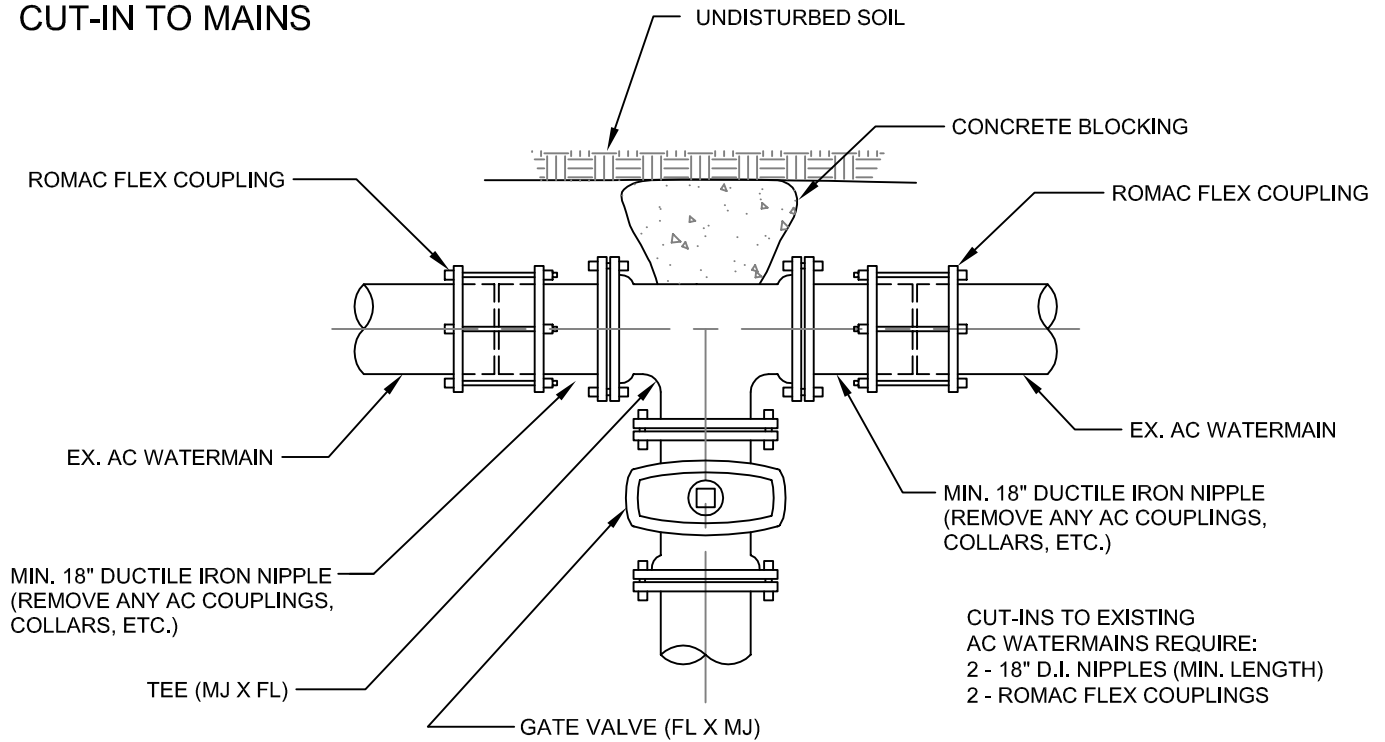

CUT-INS TO EXISTING AC WATERMAINS REQUIRE:
 2 - 18" D.I. NIPPLES (MIN. LENGTH)
 2 - ROMAC FLEX COUPLINGS

NOTES: ALL CONNECTIONS TO EXISTING MAINS WILL BE MADE WITH HWD AFTER REQUIRED TESTING.
 ANY CONNECTIONS TO RESTRAINED JOINT PIPE SHALL ALSO BE RESTRAINED JOINT.
 VALVE MARKER POST REQUIRED PER HWD STANDARD DETAIL #10.
 DISINFECT FITTINGS AND PIPE BEFORE MAKING CONNECTION.
 PROVIDE SUPPORT BLOCK UNDER TEE AND VALVE.

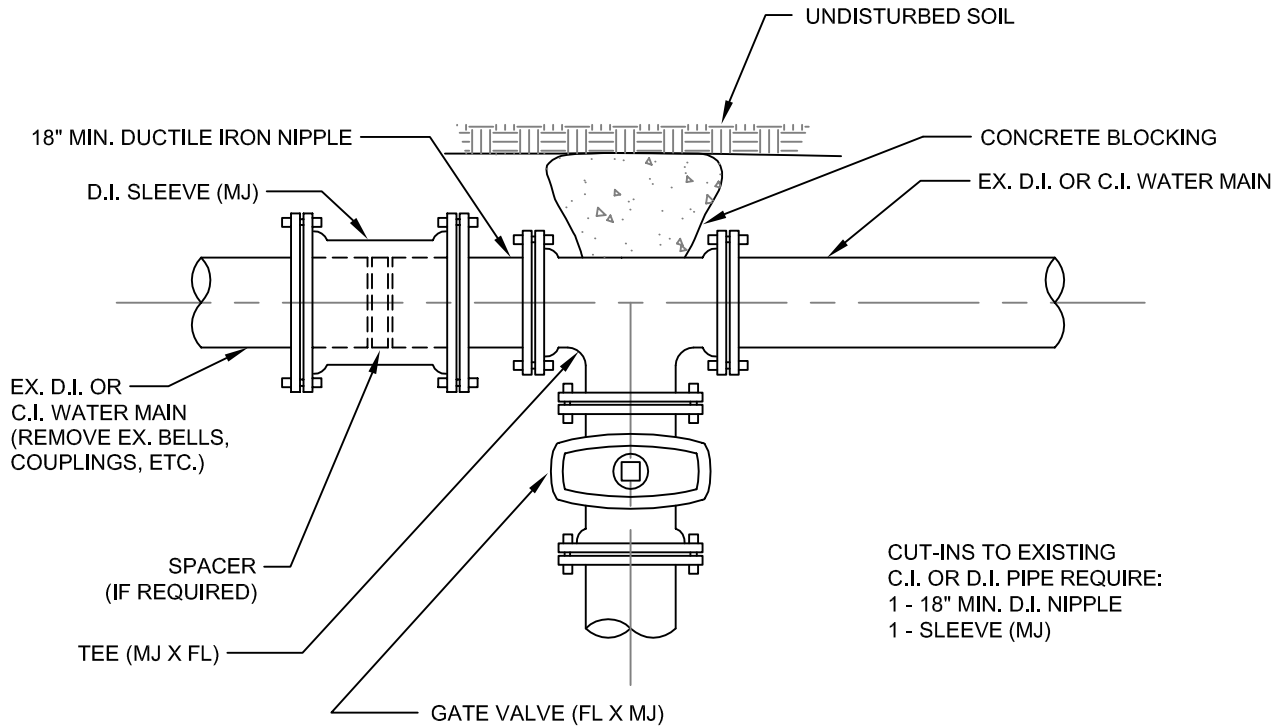

CUT-INS TO EXISTING C.I. OR D.I. PIPE REQUIRE:
 1 - 18" MIN. D.I. NIPPLE
 1 - SLEEVE (MJ)

CUT-IN USING SINGLE VALVE

NTS



REVISION DATE 1/7/04	DRAWN SED	CHECKED TDK	DISTRICT APPROVED TDK
PLOTTING SCALE NTS	FILE NAME F:\DWGS\DETAILS-2004\HWD-002	DATE APPROVED 3/1/04	